

A0 INSTALLATION DRAWING

IF THIS DOCUMENT IS PRINTED IN HARD COPY, IT IS FOR INFORMATION USE ONLY AND THEREFORE IS NOT SUBJECT TO UPDATING CONTROLS. ALWAYS REFER TO SOLIDWORKS VIEWER FOR LATEST ISSUE

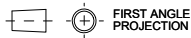

THIS DRAWING IS CONFIDENTIAL AND IS SUPPLIED ON THE EXPRESS CONDITION THAT IT SHALL NOT BE LOANED OR COPIED OR DISCLOSED TO ANY OTHER PERSON OR USED FOR ANY OTHER PURPOSE WITHOUT THE WRITTEN CONSENT OF AP RACING LTD.

AP Racing
Wheler Road
Coventry
CV3 4LB
Tel: +44 (0)24 7663 9595
Fax: +44 (0)24 7663 9599
e-mail: sales@aprac.com
Web site: HTTP://www.aprac.com

| CALIPER SPECIFICATION | |
|-------------------------------------|---|
| PISTON AREA | 11.4cm ² (PER PAD) 22.8cm ² (TOTAL) |
| DISC DIAMETER MAX | 380 (SWEEP DEPTH = 61.00") |
| DISC DIAMETER MIN | 315 (SWEEP DEPTH = 59.50") |
| DISC WIDTH MAX | CP9582-2~5S0## = 32.00 CP9582-6~9S0## = 28.00 |
| DISC WIDTH MIN (WORN CONDITION) | CP9582-2~5S0## = 31.00 CP9582-6~9S0## = 27.00 (DIFFERENTIAL WEAR NOT TO EXCEED 0.50mm SIDE TO SIDE) |
| DISC ROTATION | ROTATING DISC MUST PASS SMALLEST PISTON FIRST* |
| WORKING PRESSURES | SEE DATA SHEET P14.385 (AVAILABLE FROM AP RACING CUSTOMER SERVICES) |
| DRY WEIGHT (LESS PADS) | 3.20kg est. |
| DRY WEIGHT (INC. PADS) | 4.40kg est. |
| PAD RETENTION | 2 x FRICTION RETAINED PINS |
| RECOMMENDED WHEEL/CALIPER CLEARANCE | 4.00 (MIN) |
| RECOMMENDED PAD FRICTION MATERIAL | APF405 |
| SEAL KIT | CP4527-CC |
| ANTI-RATTLE CLIP | CP9580-119 |
| PAD RETAINING PIN | CP7715-114 |
| ELVR COMPLIANCE | ALL MATERIALS AND COATINGS COMPLY WITH END OF LIFE VEHICLES (2000/53/EC) |

| AVAILABLE PART NUMBERS | |
|-----------------------------|---------------------------------------|
| PART NUMBER | CALIPER POSITIONING |
| CP9582-2S0## / CP9581-6S0## | RIGHT HAND TRAILING (BEHIND AXLE) |
| CP9582-3S0## / CP9582-7S0## | LEFT HAND TRAILING (BEHIND AXLE) |
| CP9582-4S0## / CP9582-8S0## | RIGHT HAND LEADING (IN FRONT OF AXLE) |
| CP9582-5S0## / CP9582-9S0## | LEFT HAND LEADING (IN FRONT OF AXLE) |
| ## = COLOUR CODE | |

FOR AVAILABLE COLOURS AND FURTHER TECHNICAL INFORMATION, PLEASE REFER TO THE **PRODUCT CATALOGUE, AP RACING.COM** OR **CUSTOMER SERVICES.**

| Typical Max. Vehicle GVW as per P14.385 | | |
|---|--------------------|--------------------|
| Vehicle Configuration | | |
| Caliper Installed Position | Front Engine | Rear Engine |
| Front Axle Application | 1430 kg (3150 lbs) | 1670 kg (3680 lbs) |
| Rear Axle Application | 2510 kg (5530 lbs) | 2010 kg (4430 lbs) |

1x ANTI-RATTLE CLIP AND 2x PAD RETAINING PINS INCLUDED (NOT FITTED)

PAD PINS MUST BE REPLACED WHEN REPLACING PADS

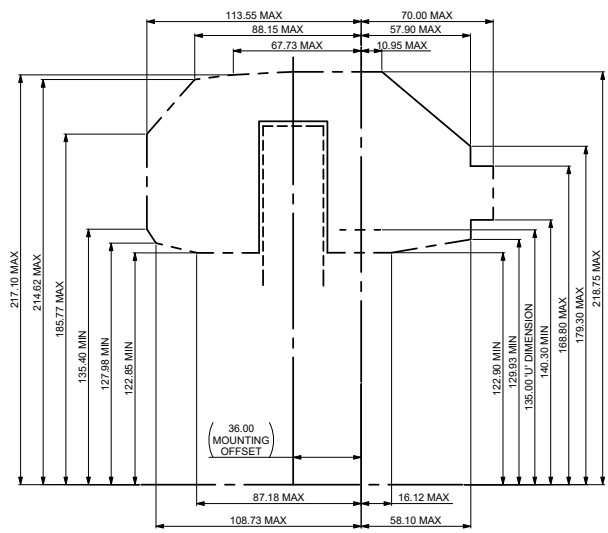
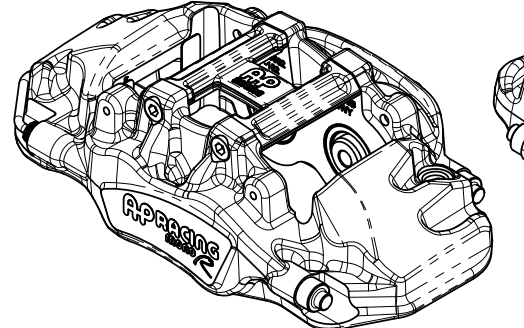

CALIPER INSTALLED PROFILE ON Ø380 DISC

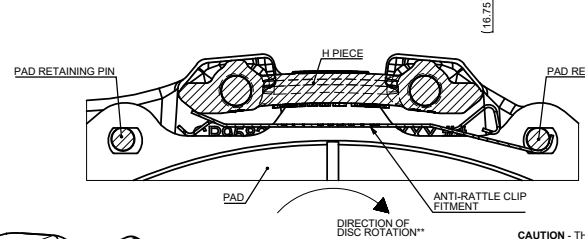
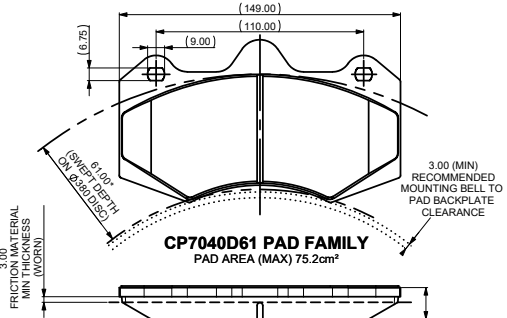

CAUTION - THE EXTERNAL PIPE IS A NON-SERVICEABLE ITEM AND MUST NOT BE TAMPERED WITH UNDER ANY CIRCUMSTANCES

FEED PORT M10 x 1.0
11.00 MIN FULL THREAD.
TYPICAL TIGHTENING TORQUE:
• FITTING WITH ONE COPPER GASKET: - 13NM + 45°
• FITTING WITH TWO COPPER GASKETS: - 13NM + 90°
RESULTING MAX TORQUE MUST NOT EXCEED 30NM

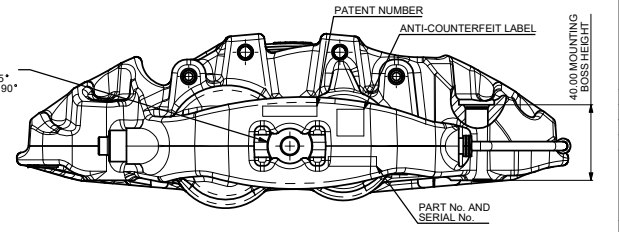
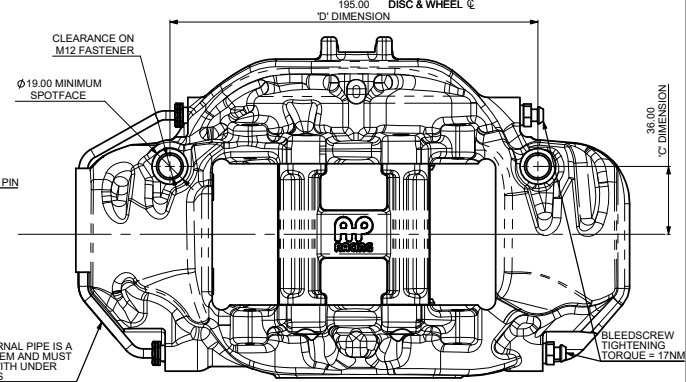
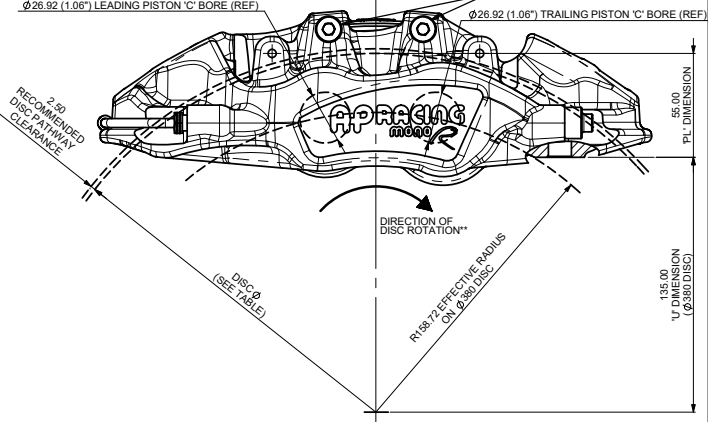
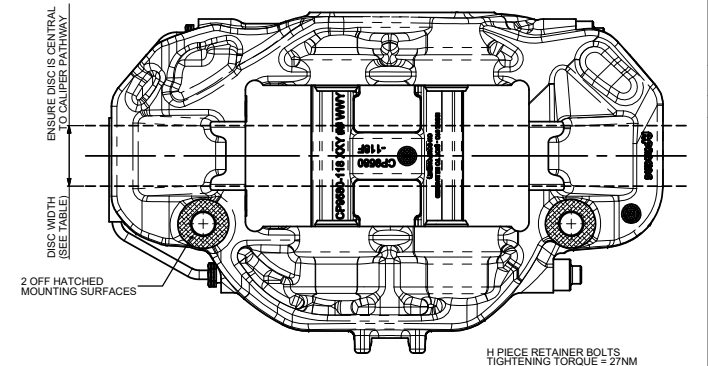

| Alterations | | | |
|-------------|---------------------|--|----|
| Rev | Date & No. | Particulars | By |
| 1 | 17/06/2019 R4637_07 | FIRST ISSUE | J2 |
| 2 | 30/10/2019 R4637_12 | ANTI-COUNTERFEIT LABEL AND LASER ETCH INFORMATION ADDED COMPATIBLE DISC INFORMATION REMOVED | J2 |
| 3 | 08/03/2021 R4637_19 | 315mm WAS 290mm 59.50mm WAS 68.00mm P14.385 WAS P14.383 GVW RATING TABLE ADDED | R2 |
| 4 | 19/08/2022 R5010_02 | AVAILABLE COLOURS REMOVED FROM SPEC TABLE. | N3 |

SCALE 1:1 SHEET 1 OF 1
DRAWN: Kris Perrey
APPROVED:
DERIVED FROM: CP9580-1CD
TITLE: 4 PISTON HPK MONOBLOC CALIPER <MOD-DIAM>26.92 x <MOD-DIAM>26.92 PISTON
DRG NO.: CP9582-1CD